

CURB MOUNT MODEL: For installation on an existing site-built curb (*Optional curb kit available)

Model #	2323	2337	2347	3737	4747
Existing Site-built Curb	25 3/4" X 25 3/4"	25 3/4" X 40"	25 3/4" X 49 3/4"	40" X 40"	49 3/4" X 49 3/4"
Inside Skylight Frame	26 1/2" X 26 1/2"	26 1/2" X 40 3/4"	26 1/2" X 50 1/2"	40 3/4" X 40 3/4"	50 1/2" X 50 1/2"
Daylight Area Glass	22 1/4" X 22 1/4"	22 1/4" X 37"	22 1/4" X 46 1/4"	37" X 37"	46 1/4" X 46 1/4"
Daylight Area sq ft	3.45 sq ft	5.72 sq ft	7.15 sq ft	9 sq ft	14.85 sq ft
Weight (approx)	21 lbs	34 lbs	48 lbs	54 lbs	89 lbs

Special sizes are available - Maxim specializes in custom sizes and shapes and provided in a fraction of the time of our competitors!
(The above sizes are most popular, but please contact Maxim for additional sizes)

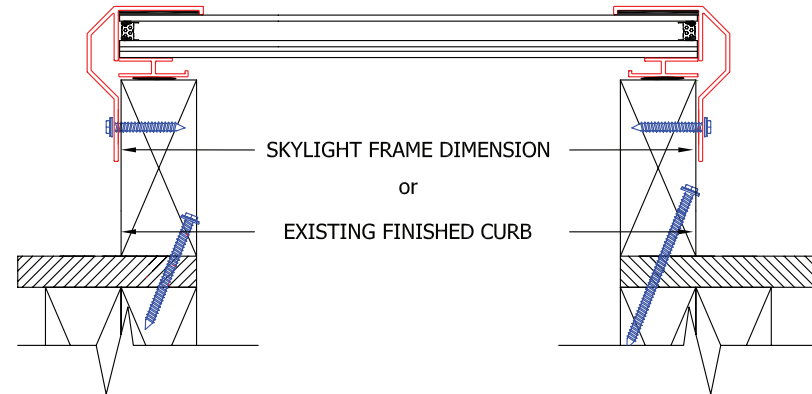

Features: One piece design for quick and easy installation. Allows installer to use site-built curb to meet specific job requirements. Interior finishing is part of the existing curb, but the skylight design allows for an unlimited number of options. Use on pitched roofs only with any type of finished roofing material. Unlimited sizes, glazing and finish options are available.

***OPTIONAL CURB KIT:** Maxim offers an optional curb assembly for installations where there is not an existing curb. A 2X6 wood curb is prefinished in white with a rigid 3/8" cellular PVC. This provides a prefinished interior or is also able to be painted to match the existing interior. The wood curb and prefinished PVC provide excellent thermal protection helping to provide the best insulation of the new skylight curb. Also included is a fully welded aluminum counter flashing that provides excellent protection against air and water infiltration. This option provides everything needed for a finished interior and exterior.



All Maxim Skylights have been tested to and conform to all or part of the following standards:
AAMA/WDMA/CSA 101/I.S.2/A440-05 (including ASTM E283, ASTM E330, ASTM E331, & ASTM E547),
ASTM E1886, ASTM E1996, TAS 201-94, TAS 202-94, TAS 203-94, and ASTM E1300-02/03

Features

- Insulated Glass for maximum energy efficiency available as Tempered, Laminated and DuPont™ Sentry Glas® Plus Impact resistant. Unlimited configurations to meet any condition. Options to meet the new 30/30 rule for energy efficiency!
- All Maxim IG comes with XL Edge® technology with the lowest failure rate in the industry - developed in part from our suppliers 45 years of experience in manufacturing IG units, 27 of these years utilizing a dual-seal silicone system.
- Mill or tough Bronze Anodized finish to protect against harsh sun and air from damaging the finish. *Clear Anodized and an unlimited number of custom powdercoat colors are also available.
- Standard, special and custom sizes available for remodeling or new construction. Also available in special shapes.
- Perfect for any residential or commercial project.
- Standard 20 year warranty for all insulated glass.

Insulated Glass Performance

LoE366 (Low E Cubed)/ Argon Gas: SHGC: 0.27 / Winter U-Factor: 0.24 / TDW (fading trans): 0.43 / LIGHT TRANS: 66%
Bronze Tint/ Argon Gas: SHGC: 0.63 / Winter U-Factor: 0.31 / TDW (fading trans): 0.52 / LIGHT TRANS: 61%
Gray Tint/ Argon Gas: SHGC: 0.63 / Winter U-Factor: 0.31 / TDW (fading trans): 0.52 / LIGHT TRANS: 61%

All insulated glass provided by Maxim includes argon gas
 All laminated impact resistant glass is manufactured with DuPont™ Sentry Glas® Plus
 Unlimited glazing colors, coatings and laminates are available
 Special insulated glass sizes and shapes are available

Frame Finishes



Bronze Anodized Mill Finish White Powdercoat Custom Color Powdercoat

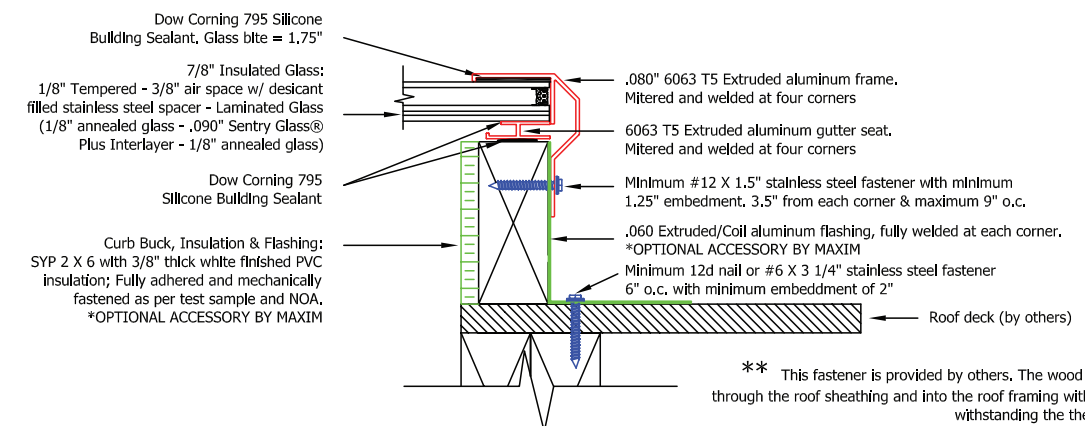
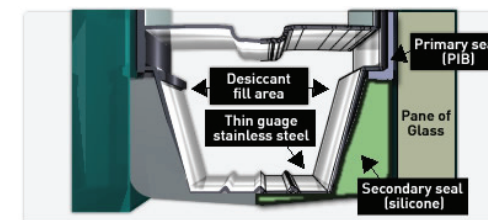

** This fastener is provided by others. The wood curb must be secured through the roof sheathing and into the roof framing with fasteners capable of withstanding the the required uplift loads.



For more information please contact Maxim Industries, Inc.

TEXAS
 Toll Free: 1.888.222.4898
 Fax: 1.214.905.2024

Web: www.maximskylights.com

FLORIDA
 Toll Free: 1.800.367.8168
 Fax: 1.561.432.3166

E-Mail: info@maximskylights.com

Designated Catastrophe Areas

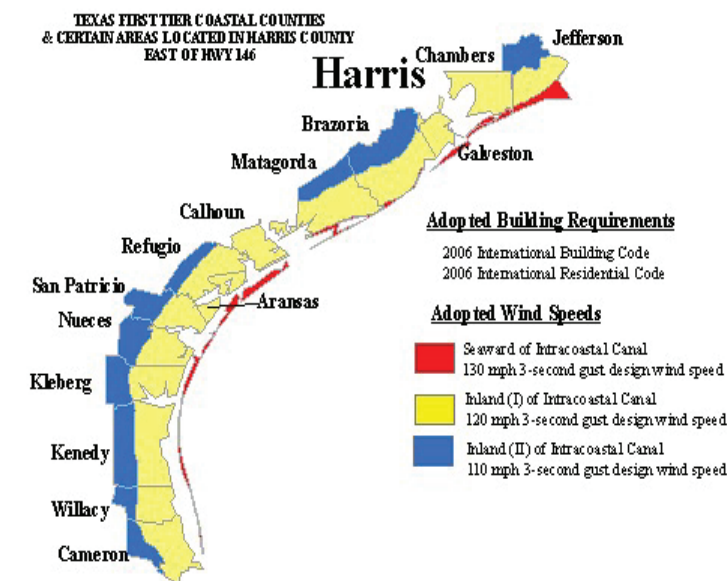

State of Florida Wind-Borne Debris Region

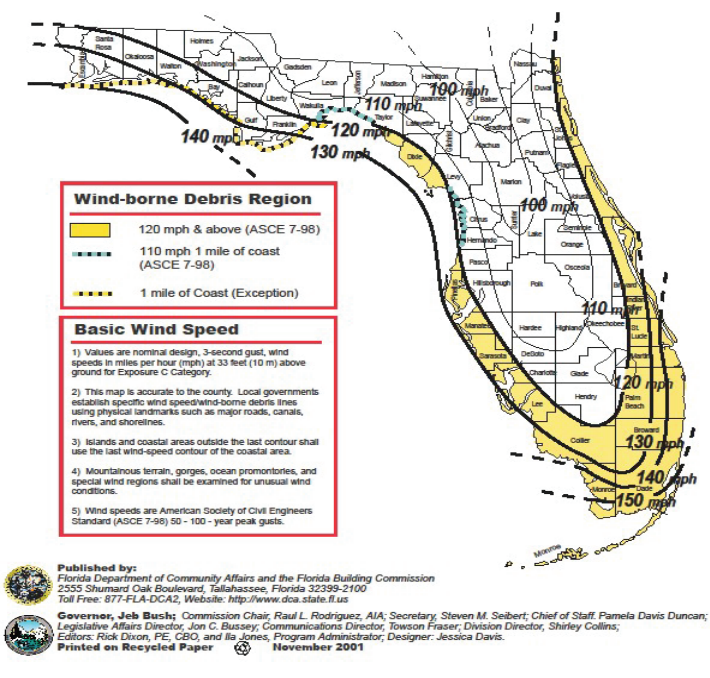

INSULATED GLASS SKYLIGHTS

Tempered, Laminated & Impact Resistant

Energy Efficiency meets Impact Resistance



TEXAS DEPARTMENT OF INSURANCE
 Product Evaluation Report SK-18

MIAMI-DADE COUNTY
 APPROVED
 NOA No.: 07-1105.02

Maxim provides the enclosed information for reference only. The manner in which our products perform is directly related to proper installation and in accordance with all local building codes. Maxim Industries, Inc. makes no warranty or guarantee of performance unless installation guidelines are followed, local and state building codes are adhered to and approval is granted by local governing officials. Specific approvals in the State of Florida and the State of Texas are provided for products that are installed in strict accordance with product details, specifications and approvals provided in addition to any product literature or information. All test data, results, approvals, details, specifications, and other product information is provided to assist the purchaser and may be updated or changed without notice. Always check that the chosen product conforms to protocols required in Florida by visiting www.miamidade.gov/buildingcode or in Texas by visiting www.tdi.state.tx.us/wind/prod/indexsk. Maxim Industries Inc. provides certain warranties for insulated glass that is provided by the glass manufacturer or a third party supplier. All insulated glass with XL Edge Technology will be covered for 20 years. Tempered safety glass may be subject to **Spontaneous glass breakage**. This is a phenomenon where tempered safety glass may spontaneously break without any apparent reason. This is rare, but may be due to slight imperfections during the manufacturing process, impact that results in stress to the glass or other defects during the manufacturing process. Laminated glass will help prevent small pieces of glass from falling in this and many other instances of impact or breakage. Specific conditions apply and a full copy of the insulated glass warranty is available upon request.

TEXAS DEPARTMENT OF INSURANCE

Approval Report SK-18

MIAMI-DADE COUNTY
 APPROVED

NOA No.: 07-1105.02

Florida
 3330 2nd Avenue North, Suite 5 Lake Worth, Florida

Corporate
 1630 Terre Colony Court Dallas, Texas 75212.6221